

>Power Team®

THE BULL
TOOLS & EQUIPMENT • ENGINEERED PRODUCTS
www.chbullco.com

PB43 SERIES PUMP

High Pressure Hydraulic 10,000PSI 60V Battery Pump



SPXFLOW®

ENGINEERED TO DELIVER RELIABILITY

Designed and Configured to Meet A Variety of Tough Applications.

The Power Team PB43 Series Hydraulic Battery Powered Pump offers high flow, a long life 8ah 60v battery, and a wide range of valve configurations. The PB43 Series pumps meet a wide array of high-pressure applications where portability, speed and performance is required.

Designed for substitution of electric, gas or air powered pumps with high flow capability. The Power Team PB43 Series Hydraulic Pump delivers the performance needed to improve productivity while keeping safety in mind.

Value Delivered.

- Industry leading, field proven, Power Team Vanguard Pump technology
- Two-stage, high-pressure (10k PSI) hydraulic pump offers quick tool advancement in the first stage with industry leading second stage mid pressure flow: 82 in3/m 2,000 PSI, 62 in3/m 7,000 PSI, 43 in3/m 10,000 PSI
- Quiet, 75 dBA at max pressure great option for indoor applications or where noise is a concern.
- 2.1HP motor provides ample power to support high-pressure performance
- Wide array of valve options allowing a hydraulic circuit that fits your exact needs
- Lightweight and portable, 72.5 lbs. with battery and oil
- Motor guard and integrated lifting handle offer increased protection and transportation to job sites hassle-free
- Ergonomic IP55 rated remote pendant with 12 ft / 3.6m cord and large button design, requiring low finger depression force to operate, decreasing operator fatigue
- 60V DC Battery, Battery charger, protective cage and valve choice included with purchase
- Reservoir size options available, refer to pump configuration page

60VDC 8Ah battery and charger Included



Unleash the force of a 60-volt battery, driving hydraulic power to new heights!

- 60-volt battery powered motor offers increased power to deliver industry leading pump flow performance
- Li-ion 60VDC, 8.0 Ah battery with 4 level battery life indicator
- 1.5 Hour battery charge time from drained to full
- 30 Minutes continuous run time with a RD106 cylinder: Extending to 10k PSI holding and retracting to 10k PSI and holding (130 cycles)
- Additional 60VDC - 8Ah Li-ion Global batteries available for purchase
- Charger available in 115VAC 60HZ
- Global battery compatible with both chargers styles

PUMP TECHNOLOGY AT A GLANCE

Many valve configurations available

Robust protective cage with carrying handle for ease of transport

Powerful 60V motor with long runtime 8Ah battery

Easy access battery compartment with protective flip up lid.

130 cycles on a RD106 cylinder to 10k PSI holding and retracting to 10k PSI and holding, providing 30 minutes of continuous run time on a single charge (1.5-hour charge time)



Deep draw reservoir with O-ring Lip for leak-free operation

Inserts for fixturing or mounting optional full roll cage

Equipped with the industry leading Vanguard™ pump technology

2-button (on/off and jog) pendant with on-board storage

TECHNICAL DIMENSIONS

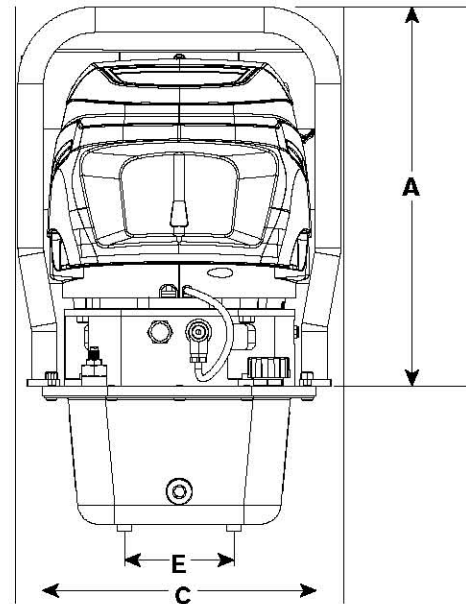
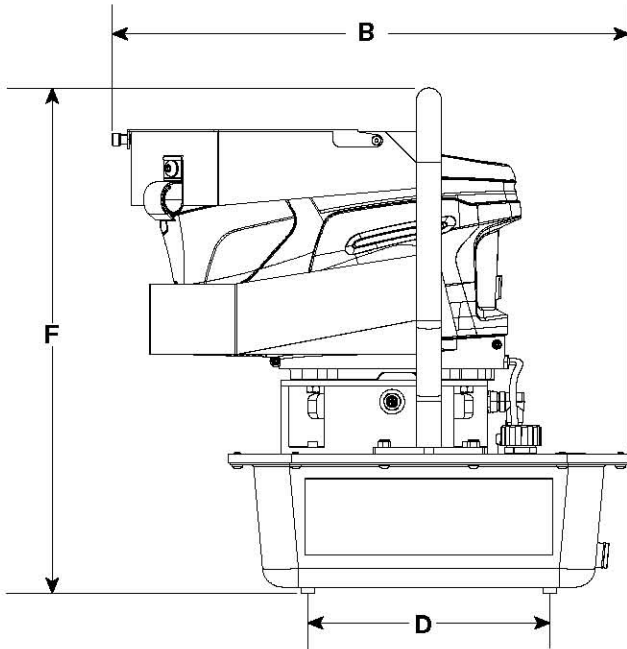
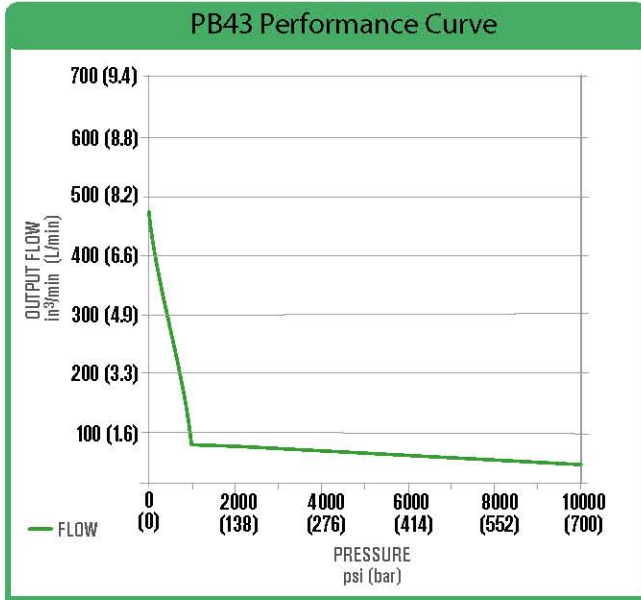

Technical Dimensions

A	B	C	D	E	F	Max Press. Output Bar (psi)	RPM	dBA at Idle and Max Press	Oil Delivery - l/min (cu.in/min) @				Wt* kg (lbs)	
									7 Bar (100psi)	35 Bar (500psi)	350 Bar (5000 psi)	700 Bar (10000 psi)		
millimeters (inches)														
374.65 (14.75)	529.59 (20.85)	318.77 (12.55)	247.65 (9.75)	107.95 (4.25)	517.39 (20.37)	700 (10,000)	3100	73 / 75	7.8 (480)	1.3 (78)	1.2 (70)	0.7 (43)	32.9 (72.5)	

Recommended operating temperature range of pump is -25°C to +50°C (-13°F to 122°F)

* Weight typical for basic unit PB43MA1P-1, including oil and battery (Charger not included in weight)

CONFIGURATIONS

Model Numbers / Ordering Information

Part Number	Reservoir size Liters (US Gal)	Usable Oil Cap. Litres (US Gal)	Valve	Cylinder Applications	Operation	Valve type	Adv/Ret	Adv/ Hold/ Ret	PosiCheck
PB43MA1P-1	5.7 (1.5)	4.8 (1.28)	9500	SA / DA	Manual	4-Way, 3-Pos. Tandem Center	No	Yes	No
PB43MD1P-1	5.7 (1.5)	4.8 (1.28)	9506	DA	Manual	4-Way, 3-Pos. Tandem Center	No	Yes	Yes
PB43MH1P-1	5.7 (1.5)	4.8 (1.28)	9520	SA	Manual	3-Way, 3-Pos. Tandem Center	No	Yes	Yes
PB43MI1P-1	5.7 (1.5)	4.8 (1.28)	9582-A	SA	Manual	3-Way, 2-Pos.	No	Yes	No
PB43ML1P-1	5.7 (1.5)	4.8 (1.28)	9628	SA / DA	Manual	Post-Tensioning	Special	No	No
PB43MA2P-1	9.5 (2.5)	8.7 (2.30)	9500	SA / DA	Manual	4-Way, 3-Pos. Tandem Center	No	Yes	No
PB43MD2P-1	9.5 (2.5)	8.7 (2.30)	9506	DA	Manual	4-Way, 3-Pos. Tandem Center	No	Yes	Yes
PB43MH2P-1	9.5 (2.5)	8.7 (2.30)	9520	SA	Manual	3-Way, 3-Pos. Tandem Center	No	Yes	Yes
PB43MI2P-1	9.5 (2.5)	8.7 (2.30)	9582-A	SA	Manual	3-Way, 2-Pos.	No	Yes	No
PB43ML2P-1	9.5 (2.5)	8.7 (2.30)	9628	SA / DA	Manual	Post-Tensioning	Special	No	No

* When ordering 115VAC 60HZ Charger use (-1) **Example: (PB43MA1P-1)**

“PLUG & PLAY” ACCESSORIES

Order No.	Description
3001185	Full Roll Cage for use with PB43 pumps Wt. 4.5kg (10lbs)
2010995	115VAC 60HZ Charger
2010994	60VDC-8Ah Li-ION Global Battery



PB43MA1P-1, LM4D, and (4) RDG556 cylinders (Typical - 4-point, double acting with point flow control system)

CUSTOMER SERVICE CENTERS

Rockford, Illinois USA
5885 11th Street
Rockford, IL 61109 USA
Tel: +1 815 874 5556
Fax: +1 800 288 7031
info@spxboltingsystems.com

Gonzales, Louisiana USA
3141 S. Darla Avenue
Gonzales, LA 70737 USA
Tel: +1 225 774 0888
Fax: +1 225 450 2211
louisiana@spxboltingsystems.com

Houston, Texas USA
310 E. Pasadena Frwy
Pasadena, TX 77503 USA
Tel: +1 713 472 2500
Fax: +1 713 472 2501
houston@spxboltingsystems.com

Corpus Christi, Texas USA
318 E. Centaurus Street
Corpus Christi, TX 78405 USA
Tel: +1 361 371 6516
Fax: +1 361 687 2533
corpus.christi.sc@spxboltingsystems.com

Europe
Albert Thijsstraat 12
6471 WX Eyselshoven
The Netherlands
Tel: +31 45 567 8877
Fax: +31 45 567 8878
europe@spxboltingsystems.com

India
SPX Flow Technology (India)
Pvt. Limited Survey No. 275
Odhav, Ahmedabad - 382 415
Tel: +91 99099 85454
Fax: +91 97277 19950
india@spxboltingsystems.com

South East Asia
20 Pioneer Crescent #06-01,
West Park BizCentral
Singapore 628555
Tel: +65 6265 3343
Fax: +65 6265 6646
singapore@spxboltingsystems.com

China
7F Treasury Building
1568 Hua shan Road
Shanghai, 200052 China
Tel: +86 21 2208 5660
Fax: +86 21 2208 5682
china@spxboltingsystems.com

Australia
SPX Flow Technology
Australia Pty. Ltd.
Quad 2, 6 Parkview Drive
Homebush Bay NSW 2127
Tel: +61 02 9763 4900
Fax: +61 02 9763 7888
ft.aus.cs@spxflow.com





Distributed by: **C H BULL CO.**
229 UTAH AVE.
SOUTH SAN FRANCISCO, CA. 94080
(650) 837-8400

OR

C H BULL CO.
511 HARBOR BLVD. SUITE A
WEST SACRAMENTO, CA. 95691
(916) 617-2656

SPXFLOW®

SPX FLOW, Inc. reserves the right to incorporate our latest design and material changes without notice or obligation. Design features, materials of construction and dimensional data, as described in this bulletin, are provided for your information only and should not be relied upon unless confirmed in writing. Please contact your local sales representative for product availability in your region. The green "➤" is a trademark of SPX FLOW, Inc.

For more information, visit www.spxflow.com.

