

Main Components

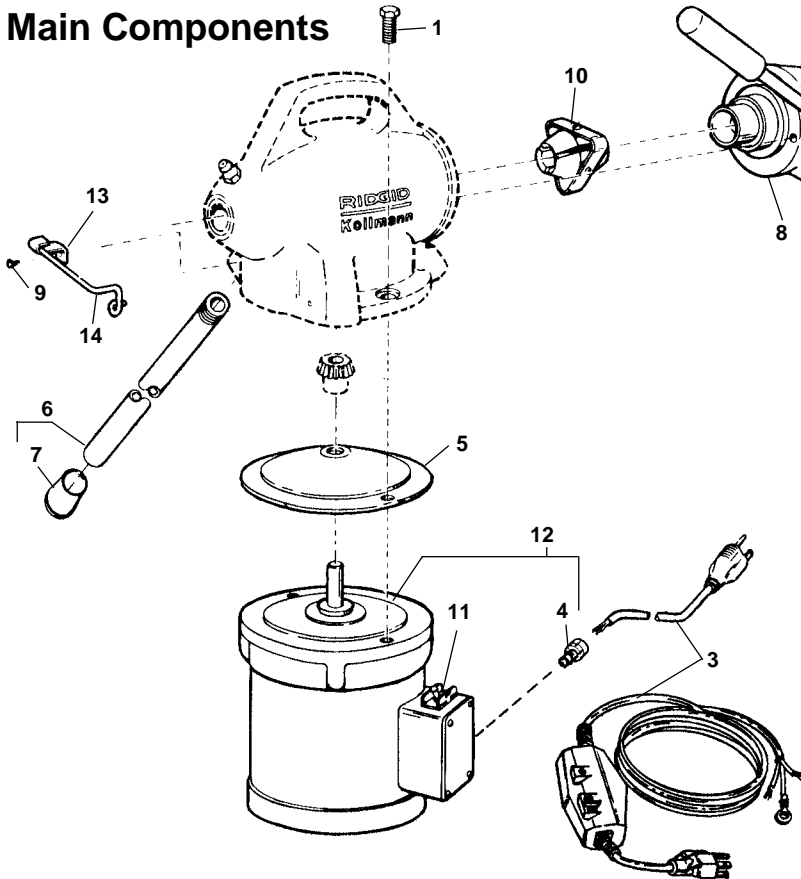

NOTE: Order parts by Catalog Number only. DO NOT order by Reference Number.

Ref. No.	Catalog No.	Description
1	59785	Screw (2)
2	60910	Screw (2)
3	50507	Cord with GFCI
	27656	Cord (Europe)
4	41147	Strain Relief
5	61935	Insulating Motor Gasket
6	59825	Legs w/Rubber Feet (3 per set) (Incl. Ref. No. 7)
7	59965	A-2240 Rubber Feet (3)
8	59975	A-2244-X Rack and Pinion Assembly
9	59990	A-2256 Screw (2)
10	59450	A-3179 Clutch Jaw Assembly
11	95845	Switch DPDT - 6 Terminal (Emerson Motor)
	41817	Switch 3PDT - 9 Terminal (Emerson Motor)
	24236	Switch (Europe)
12	69265	Motor Assembly - 115V (Incl. Ref. Nos. 4 and 11)
	16716	Motor Assembly (230V Europe)
*	31336	Motor Shaft Seal (Europe)
*	31346	Switch Cover (Europe)
*	24246	Switch Box (Europe)
*	29976	Run Capacitor (Europe)
13	89800	Catch
14	89805	Pin
15	84507	K-50 Contact Switch (Emerson Motor Only -Part Not Shown)

* Parts Not Shown - Europe Only

Bevel Gear and Related Parts

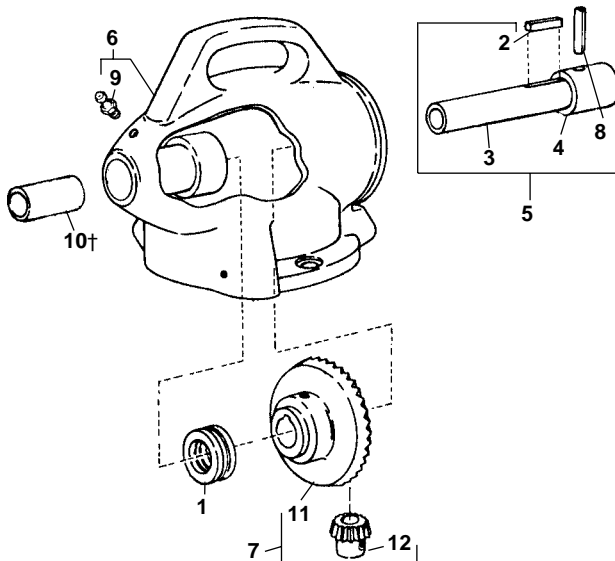

Ref. No.	Catalog No.	Description	Ref. No.	Catalog No.	Description
1	59945	Bearing	7	60985	Bevel and Pinion Gear w/Set Screws
2	60680	Key	8	76830	Spring Pin
3	61570	Shaft	9	89810	Grease Fitting
4	61575	Cone	10†	61715	Bronze Bushing
5	59695	Shaft with Cone	11	24577	Bevel Gear w/Key
6	59960	Body	12	24572	Pinion Gear w/Key

† Service Note: After replacing Bronze Bushing a 1/4" drill bit must be used for drilling a grease hole port for grease fitting.

Rack and Pinion Assembly No. A-2244

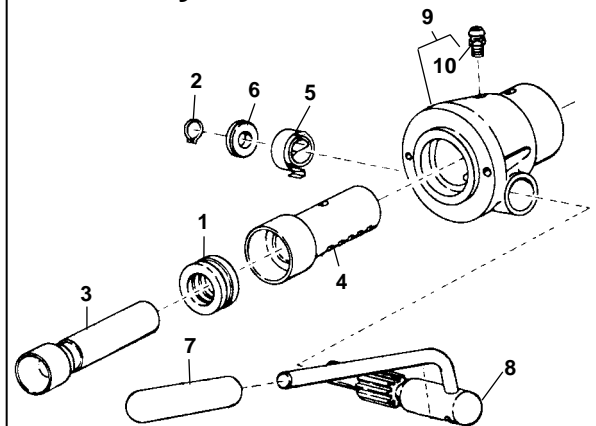

Ref. No.	Catalog No.	Description
-	59975	Rack & Pinion Assembly
1	59945	Bearing
2	60860	Retaining Ring
3	61580	Rear Clutch Cone Sleeve
4	61585	Gear Rack
5	61595	Pinion Spring
6	61600	Pinion Stem Washer
7	61605	Handle Grip
8	59980	Handle with Pinion Assembly
9	60965	Rack and Pinion Housing (Incl. Ref. No. 10)
10	89810	Grease Fitting