

Main Components

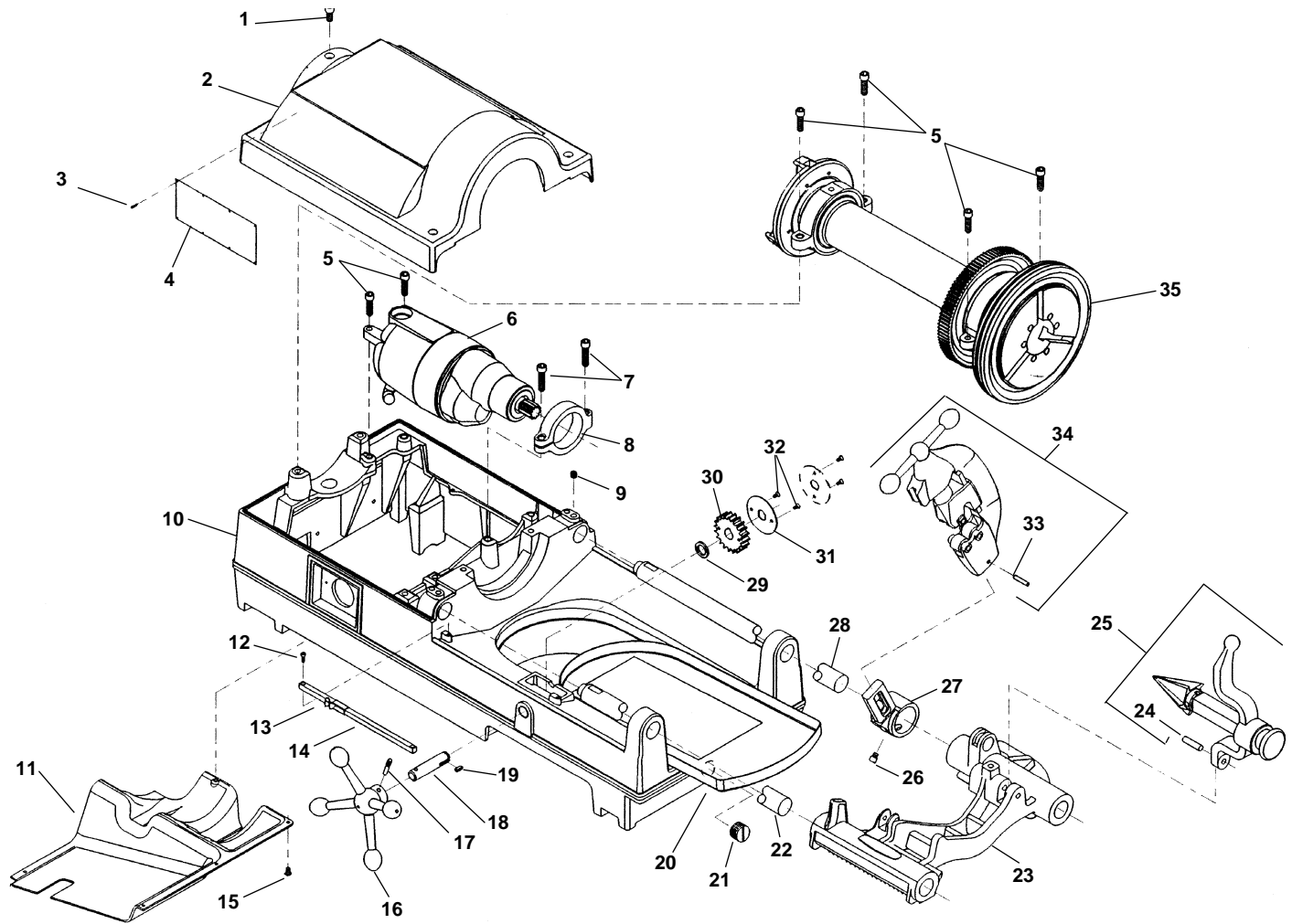

**NOTE: Order parts by Catalog Number only.
DO NOT order by Reference Number.**

Ref. No.	Catalog No.	Description	Ref. No.	Catalog No.	Description
1	46760	Screw (3)	18	47115	Pinion Shaft
2	62062	Top Cover	19	46930	Key $\frac{3}{16}$ " Sq. x $\frac{1}{2}$ "
3	85920	Pop Rivet (8)	20	43355	Chip Tray
4	88690	Warning Plate	21	48337	Drain Plug
5	46745	Screw	22	45440	Front Support Bar
6	64447	1194 Motor, 115V, 36 RPM	23	62057	Carriage Assembly
—	64452	1194 A Motor, 115V, 54 RPM	24	47065	Hinge Pin
—	64457	2394 Motor, 230V, 36 RPM	25	42365	341 Reamer Assembly
7	44220	Screw (2)	26	44930	Stop Screw
8	43795	Motor Bracket	27	43690	Cutter Arm
9	46800	Set Screw (2)	28	45220	Rear Support Bar
10	61952	Base	29	47145	Spacer
11	61947	Bottom Cover	30	45430	Pinion Gear
12	45615	Screw (2)	31	47120	Lock Plate
13	47110	Indicator Slide	32	46785	Screw 10 - 32 x $\frac{3}{8}$ " (2)
14	47105	Indicator Bar	33	47135	Stop Pin
15	45420	Screw (5)	34	42390	820 Cutter Assembly
16	46510	Handwheel	35	47585	Drive Shaft Assembly
17	47165	Pin			