

Power Assembly/Drive Assembly Separation Procedure

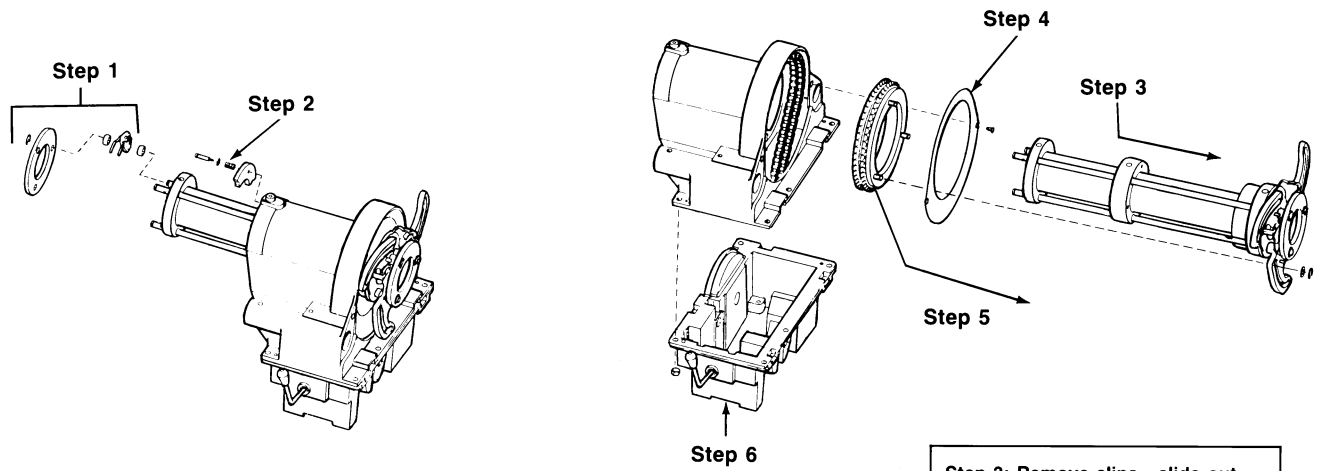

Step 1: Remove Rear Centering Device.

Step 2: Remove Brake Shoes (3).

Step 3: Remove clips - slide out Spindle Assembly.

Step 4/5: Remove Splash Guard and Sprocket.

Step 6: Separate housings.

Motor Mounting and Transmission Shifter Assembly (Induction Only)

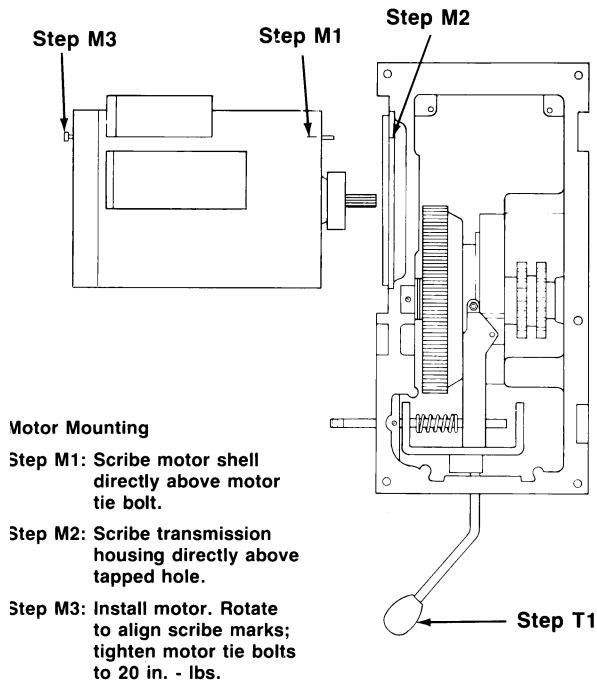

Motor Mounting

Step M1: Scribe motor shell directly above motor tie bolt.

Step M2: Scribe transmission housing directly above tapped hole.

Step M3: Install motor. Rotate to align scribe marks; tighten motor tie bolts to 20 in. - lbs.

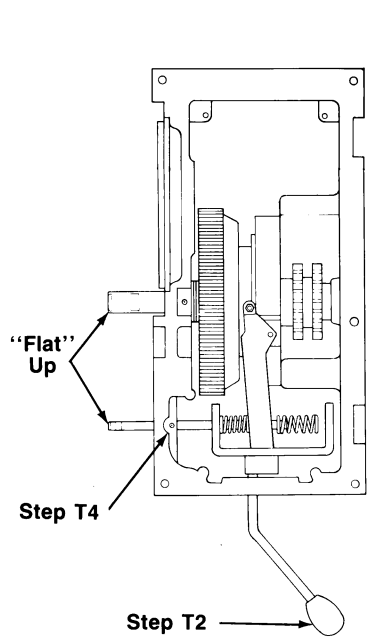

Transmission Shifter Assembly

Step T1: Rotate shift lever to left and install small (short) spring over shifting shaft.

Step T2: Rotate shift lever to right and install large (long) spring.

Step T3: (Not shown) Rotate shift lever to center (upright) position and finish installing shaft.

Step T4: Tighten set screw.

Note: Install "flat" on shafts UP.

