

60 Hz Electrical Components

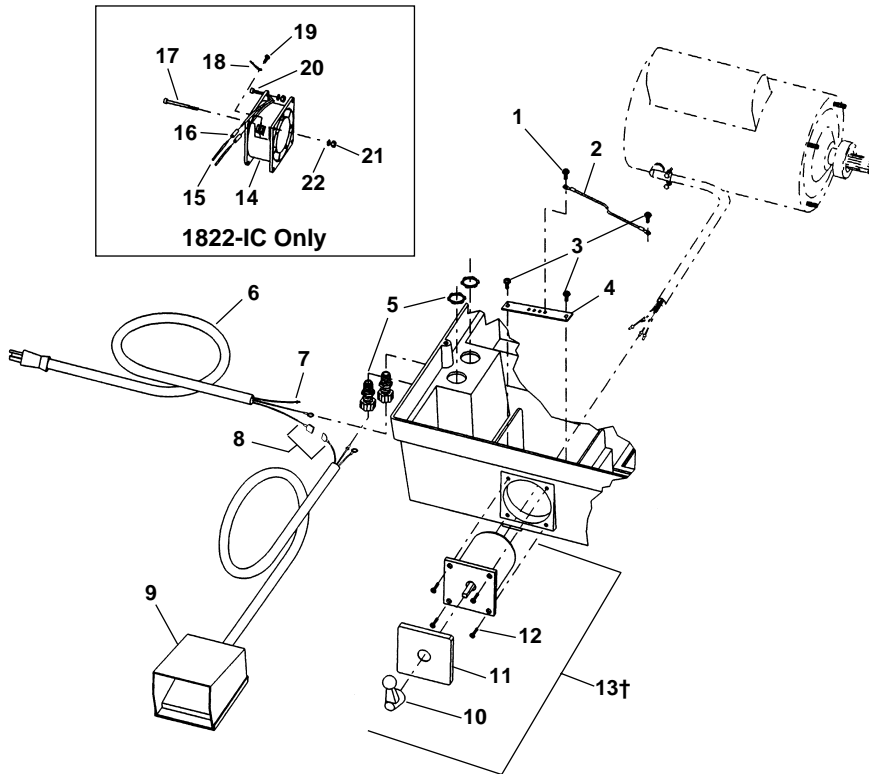

NOTE: Order parts by Catalog Number only. DO NOT order by Reference Number.

Ref. No.	Catalog No.	Description
1	34715	Screw 10-32 x 3/8" (3)
2	33607	Ground Wire
3	45420	Screw 10-24 (4)
4	59732	Ground Strap
5	68885	Strain Relief (2)
6	46740	Power Cord 120V
	46410	Power Cord 240V
7	36222	Wire Terminal
8	56407	Quick Disconnect Set
9	36642	B-294 Foot Switch
10	59707	Switch Knob
11	59737	Switch Plate
12	59727	Screw 8-32 x 3/4" Fl. Head (4)
13†	59757	Switch Assembly
14	35232	Fan Assembly
15	35242	Fan Wire (2)
16	35237	Wire Connector (2)
17	35247	Screw 10-32 x 2 1/4" (2)
18	35227	Fan Ground Wire
19	45525	Screw
20	35302	Screw 8-32 x 1/2"
21	85945	Ext. Tooth Washer #8 (4)
22	76190	Hex Nut - #8 (4)

1224 & 1822-I Replacement Switch Wiring Diagram

