

Carriage and Chip Pan

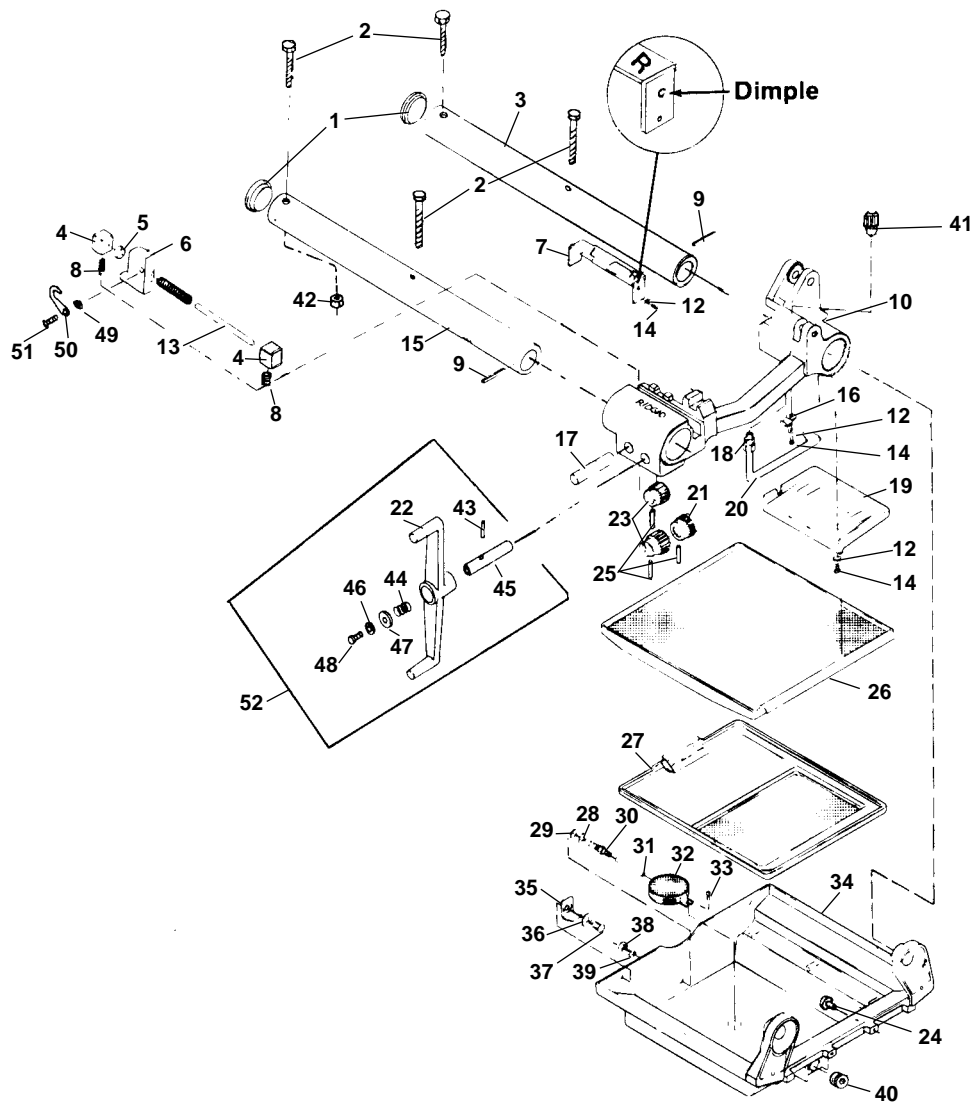

**NOTE: Order parts by Catalog Number only.
DO NOT order by Reference Number.**

Ref. No.	Catalog No.	Description	Ref. No.	Catalog No.	Description	Ref. No.	Catalog No.	Description
—	49992	Carriage Assembly (Includes Ref. #4-8, 10-14, 17, 21, 23, 25, 41, 49-52)	17	26777	Sine Bar/Pinion Shaft (2)	36	40930	Lock Washer 3/8" (2)
1	26502	Rail Plug (2)	18	26562	Supply Line Fitting	37	26997	Screw 3/8" - 16 x 3/4" (2)
2	40167	Bolt 5/16" - 18 x 3 1/2" (4)	19	26772	Drip Plate	38	83545	Hex Nut 3/8" - 16
3	49982	Rear Rail	20	26812	Die Lubrication Tube	39	26307	Washer
4	26787	Guide Block (2)	21	26587	Sine Bar Pinion	40	48337	Drain Plug
5	26792	Sine Bar Spacer	22	40147	Carriage Handwheel	41	28462	Ball Detente
6	40242	Sine Bar	23	26572	Carriage Pinion (2)	42	27517	Lock Nut 5/16" - 18 (4)
7	26912	Sine Bar Cover Assembly	24	26837	Stud (2)	43	74965	Pin
8	26582	Guide Block Spring (2)	25	74965	Roll Pin 1/4" x 1 1/4" (3)	44	89530	Spring
9	27052	Roll Pin (2)	26	26802	Draw Tray Assembly	45	40157	Handwheel Shaft
10	49987	Carriage (Includes Ref. #41)	27	26807	Insert Assembly	46	41582	Lock Washer
11	26592	Sine Bar Return Spring	28	27252	Washer	47	40152	Washer
12	41592	Washer #10 (2)	29	41715	Seal Washer	48	26997	Screw
13	26577	Guide Bar	30	26697	Bulk Head Fitting	49	40227	Spring Washer
14	79965	Screw #10 - 32 x 1/2" (5)	31	26927	Tubing	50	40237	Latch
15	49977	Front Rail	32	27262	Screen Assembly	51	40232	Spiral Pin
16	26652	Oil Supply Clamp	33	26797	Screw #10 - 32 x 5/16"	52	42027	Handwheel Kit
			34	26847	Chip Pan Hanger Assembly			
			35	26817	Chip Pan Bracket (2)			